

AGENDA

**LVWA BOARD OF TRUSTEE WORKSHOP MEETING
WEDNESDAY, JANUARY 18, 2017
WILLOW HALL**

1:00PM

Pledge of Allegiance

APPEARANCES: Tom Mitchell from Mitchell Insurance

DIVISION REPORTS

Architectural Division	(Tom Hardman)
Resident Services	(Sara Zitelli)
Finance Division	(Mary Lou Doner)
Administration Division	(Trustee Liaison S. Kaufman)

COMMUNITY MANAGER'S REPORT

RECREATION REPORT

UNFINISHED BUSINESS

1. Hotwire Services
2. Willow Gazebo/ Pier Engineering
3. Willow Patio Renovation – Presentation

NEW BUSINESS

1. Resolution – Excess Income Applied to the Following Year's Assessment
2. Vinyl Cutter/ Plotter Sign Machine
3. Hot Water Pressure Washer with Trailer
4. Association Office HVAC Replacement

Audience comments

In general, audience questions and comments should be addressed to the interest of all residents. For resolution of personal or maintenance issues, contact the Department Manager or the Manager of Resident Services and, if necessary, the Community Manager.



MITCHELL Insurance Services Inc.

TO: All Leisure Village West Unit Owners

RE: Association Insurance Program

DATE: April 15, 2016

Following is a brief outline of the property insurance carried by your association as written through Philadelphia Insurance Company:

In accordance with your association's governing documents, all buildings comprising Leisure Village West Association are insured on an "Original Specifications" basis with a Replacement Cost valuation provision. Put simply, this means that each unit is covered in its entirety in accordance with the builder's original specifications subject to the policy limit (less any applicable deductible). Deductibles are applied on a *per occurrence* basis (currently \$5,000). In accordance with your governing documents, each owner shall be responsible for the deductible applicable to damages to that part of the unit which they are responsible to replace, repair or maintain. Coverage is written on a "Special Perils" basis meaning that all perils are covered except those specifically excluded such as (but not limited to) Flood, Earthquake, Nuclear Accidents, and War. (Additional coverage may have been purchased to delete one or more of these exclusions.)

While very broad in scope, the association's master policy is not intended to cover personal property, loss of use (temporary rental assistance), loss assessment, upgrades or improvements made by any unitowners (past or present), or their personal liability. In light of this, it is highly recommended that each owner and/or tenant consult with their insurance professional and provide them with the above information when determining their personal insurance needs. If desired, our office would be pleased to provide you with a competitive quotation. You may reach us by calling (732) 738-5500 or emailing us at info@mitchellinsservices.com.

Finally, please remember that all claims must be promptly reported to the management office.

Leisure Village West Association

AT MANCHESTER, NEW JERSEY

RESOLUTION

EXCESS INCOME APPLIED TO THE FOLLOWING YEAR'S ASSESSMENT

WHEREAS, Leisure Village West Association, Inc. is a New Jersey corporation duly organized and existing under the laws of the State of New Jersey; and

WHEREAS, the members desire that the corporation shall act in full accordance with the rulings and regulations of the Internal Revenue Service;

NOW THEREFORE, the members hereby adopt the following resolution by and on behalf of the Leisure Village West Association.

BE IT RESOLVED, that any excess of membership income over membership expenses for the year ended September 30, 2016 shall be applied against the subsequent tax year member assessments as provided by IRS Revenue Ruling 70-604.

This resolution is adopted and made part of the minutes of meeting of February 1, 2017.

Elaine Baumeister,
Board Secretary

:sb



Leisure Village® West Association

AT MANCHESTER, NEW JERSEY

Interoffice Memorandum

To: Board of Trustees
From: Howard Height
Date: December 13, 2016
Re: Vinyl Cutter / Plotter sign machine

I have been asked to research the costs to replace our Vinyl Cutter/ Plotter. Our current vinyl cutter (sign machine) is housed in the maintenance office and is used for making signage used throughout the village. It is a Bren model 924, which is 17 years old and is no longer supported by the manufacturer. Sub-sequentially it is also no longer functioning properly. I have gone out to bid for a new Graphtec CE-6000 Vinyl Cutter / Plotter with a supply of Vinyl sign material in various colors. Below are the quotes received:

All quotes include tax and shipping

Vendor		Price
Sign Warehouse	Graphtec CE6000 48"/ software / vinyl supplies	\$ 4,882.61
U.S. Cutter	Graphtec CE6000 48"/ software / vinyl supplies	\$ 5,102.28
Beacon Graphics	Graphtec CE6000 48"/ software / vinyl supplies	\$ 5,384.66

It is my recommendation to purchase the Graphtec CE6000 48" Vinyl Cutter/ Plotter, software and vinyl supplies from Sign Warehouse for \$4,882.61. This expense will be charged to GL# 3150 – Property Replacement Fund.



Howard Height

From: Shacreda Smith [shacreda.smith@signwarehouse.com]
Sent: Friday, November 18, 2016 11:50 AM
To: hheight@lwservice.com
Subject: SignWarehouse, Inc.: Quote #42760



SignWarehouse, Inc.
 2614 Texoma Drive
 Denison TX 75020
Bill To
 Howard Height
 1200 Rt 70
 Manchester Township NJ 08759

Quote

Date: 11/18/2016
Estimate #: 42760
Expires: 12/18/2016
Exp. Close: 11/18/2016
Sales Rep: Shacreda Andrews
Location: 000 - Denison
LAYAWAY: No
Shipping Method: UPS® Ground

Item	Quantity	Units	Serial/Lot Numbers	Description	Options	Rate	Tax	Amount
PLT-CE6000-120	1			GRAPHTEC CE6000 48" CUTTER & STAND		3,895.00	Yes	3,895.00
VE-LXI-EXP-12	1			VINYL EXPRESS LXI EXPERT 12		795.00	Yes	299.00
VOR651-4810-010	1			ORACAL 651 48X10 WHITE NP	VOR Colors: 010 - WHITE	54.95	Yes	44.23
VOR651-4810-070	1			ORACAL 651 48X10 BLACK NP	VOR Colors: 070 - BLACK	44.23	Yes	44.23
M-AP-GXP575-SW-30	1			ENDURA PERFECT TEAR 30" X 100 YD (501520)		70.39	Yes	70.39
VOR651-3010-070	1			ORACAL 651 30X10 BLACK	VOR Colors: 070 - BLACK	28.75	Yes	28.75
VOR651-3010-010	1			ORACAL 651 30X10 WHITE	VOR Colors: 010 - WHITE	28.75	Yes	28.75
VOR651-3010-049	1			ORACAL 651 30X10 KING BLUE	VOR Colors: 049 - KING BLUE	32.95	Yes	32.95
VOR651-3010-032	1			ORACAL 651 30X10 LIGHT RED	VOR Colors: 032 - LIGHT RED	32.95	Yes	32.95
VOR651-3010-613	1			ORACAL 651 30X10 FOREST GREEN	VOR Colors: 613 - FOREST GREEN	32.95	Yes	32.95
VOR651-3010-312	1			ORACAL 651 30X10 BURGUNDY	VOR Colors: 312 - BURGUNDY	32.95	Yes	32.95
VOR651-3010-021	1			ORACAL 651 30X10 YELLOW	VOR Colors: 021 - YELLOW	32.95	Yes	32.95
VOR651-3010-082	1			ORACAL 651 30X10 BEIGE	VOR Colors: 082 - BEIGE	32.95	Yes	32.95
VOR651-3010-053	1			ORACAL 651 30X10 LIGHT BLUE	VOR Colors: 053 - LIGHT BLUE	32.95	Yes	32.95
VOR651-3010-045	1			ORACAL 651 30X10 SOFT PINK	VOR Colors: 045 - SOFT PINK	32.95	Yes	32.95
VOR651-3010-062	1			ORACAL 651 30X10 LIGHT GREEN	VOR Colors: 062 - LIGHT GREEN	32.95	Yes	32.95
VOR651-	1			ORACAL 651 30X10	VOR Colors: 066	32.95	Yes	32.95

3010-066			TURQUOISE BLUE	- TURQUOISE BLUE			
VOR651-3010-091	1		ORACAL 651 30X10 GOLD	VOR Colors: 091 - GOLD METALLIC	37.89	Yes	37.89
VOR651-3010-090	1		ORACAL 651 30X10 SILVER GRAY	VOR Colors: 090 - SILVER GRAY METALLIC	37.89	Yes	37.89
VOR651-3010-040	1		ORACAL 651 30X10 VIOLET	VOR Colors: 040 - VIOLET	32.95	Yes	32.95
M-AP-GXP575-SW-03	1		ENDURA PERFECT TEAR 3" X 100 YD (501872)		7.05	Yes	7.05
M-AP-GXP575-SW-06	1		ENDURA PERFECT TEAR 6" X 100 YD (501875)		14.09	Yes	14.09
M-AP-GXP575-SW-12	1		ENDURA PERFECT TEAR 12" X 100 YD (501513)		28.15	Yes	28.15
M-AP-GXF101-08	1		GXF101 PREVIEW PLUS 8" X 100 YD (502671)		25.05	Yes	25.05
HT-SW-TWEEZER	1		SIGNWAREHOUSE TWEEZER (TZ10WOP)		4.59	Yes	4.59
PLTB-GRAP-CB09U	1		SW CUSTOM BLADE FOR GRAPHTEC - CB09U 45 BLADE		11.00	Yes	11.00
PLTA-PHP33-CB09N-HS	1		.9MM GRAPHTEC BLADE HOLDER- BLUE TOP / BLACK ABS TIP (PHP33-CB09N-HS)		107.00	Yes	107.00
PLTP-SG20BK-G	1		PRESSURIZED BALLPOINT PEN BLACK (53001-069)		15.79	Yes	15.79
Partner Discount					-600.00	Yes	-600.00
UPS® Ground	1		UPS Ground		108.91	Yes	108.91
					Total \$4,570.21		

Here is your quote with shipping included. Please call me with any questions you may have.

TAX 312.40

4882.61



BEACON Graphics

www.BeaconGraphics.com

189 Melster Ave Branchburg, NJ 08876 - 908.231.8077

PROPOSAL

SQ-413058

9/14/2016



Customer

Cleisure Village West
Howard Heights
989 Buckingham Manchester
LANEHURST NJ 07759

Contact

Ship To

Cleisure Village West
Howard Heights
989 Buckingham Manchester
LANEHURST NJ 07759

Account	Terms	Due Date	Account Rep	Schedule Date
201185	PREPAID	9/14/2016	Dave Lynn	9/14/2016

Quotation	PO #	Reference	Ship VIA	Page	Printed
SQ-413058			UPS Ground (up to 5 lbs)	1	9/15/2016 11:01:00AM

L Item	Description	Qty	Price	UM	Discount	Amount
1	CE6000-100 GRAPHTEC 48" E-CLASS CUTTER W/STAND Must Register Within 30 Days at http://www.graphtecamerica.com/graphtec-america-product-product-registration-ce6000-series-registration for Free 2nd Year Warranty	1	\$3,395.00	EA	\$200.00	\$3,195.00
2						
3						
4	ULTRA-FLEX-LITE ULTRA-FLEX LITE CLOVE CUTTING SOFTWARE Software download. Activation email will be sent to:	1	\$695.00	EA	\$200.00	\$495.00
5						
6						
7	FV5014810 VECTOR PRO-V5 GLOSS WHITE UMF 48"X10 YD	1	\$44.50	EA	\$4.45	\$40.05
8	FV5024810 VECTOR PRO-V5 GLOSS BLACK UMF 48"X10 YD	1	\$44.50	EA	\$4.45	\$40.05
9						
10	V4823000 VECTOR DIAMONDBACK STD 30"X10YD	1	\$75.50	EA	\$7.55	\$67.95
11						
12						
13	VK-30 VECTOR 30" START UP KIT	1	\$224.40	EA	\$144.88	\$79.52
14	FV5013010 VECTOR PRO-V5 GLOSS BLACK UMF 30"X10 YD	1	\$0.00	EA		\$0.00
15	FV5013010 VECTOR PRO-V5 GLOSS WHITE UMF 30"X10 YD	1	\$0.00	EA		\$0.00
16	FV5083010 VECTOR PRO-V5 GLIMING BLUE UMF 30"X10 YD	1	\$0.00	EA		\$0.00
17	FV5333010 VECTOR PRO-V5 LIGHT RED UMF 30"X10 YD	1	\$0.00	EA		\$0.00
18	FV5143010 VECTOR PRO-V5 FOREST GREEN UMF 30"X10 YD	1	\$0.00	EA		\$0.00
19	FV5343010 VECTOR PRO-V5 BURGUNDY UMF 30"X10 YD	1	\$0.00	EA		\$0.00
20	FV5143010 VECTOR PRO-V5 YELLOW UMF 30"X10 YD	1	\$0.00	EA		\$0.00
21	FV5313010 VECTOR PRO-V5 BEIGE UMF 30"X10 YD	1	\$0.00	EA		\$0.00
22	FV5143010 VECTOR PRO-V5 LT.BLUE UMF 30"X10 YD	1	\$0.00	EA		\$0.00
23	FV5413010 VECTOR PRO-V5 SOFT PINK UMF 30"X10 YD	1	\$0.00	EA		\$0.00
24	FV5203010 VECTOR PRO-V5 LIGHT GREEN UMF 30"X10 YD	1	\$0.00	EA		\$0.00

NOTE: All shipping/handling amounts are estimates and subject to change. You will be invoiced the actual amount of Shipping/Handling when your order is shipped.

Page 1

Equipment orders in excess of \$5,000 are subject to a 3% processing fee when using a Credit Card for purchase.

Sub Total \$4,617.39

All quotes are valid for 30 days unless otherwise specified.



BEACON Graphics

www.BeaconGraphics.com

189 Melster Ave Branchburg, NJ 08876 - 908.231.8077

PROPOSAL

SQ-413058

9/14/2016



Customer

Contact

Ship To

Discure Village West
Howard Heights
909 Buckingham Manchester
LANESHOP NJ 08879

Discure Village West
Howard Heights
909 Buckingham Manchester
LANESHOP NJ 08879

Account	Terms	Due Date	Account Rep	Schedule Date
---------	-------	----------	-------------	---------------

201185

PREPAID

9/14/2016

Dave Lynn

9/14/2016

Quotation	PO #	Reference	Ship VIA	Page	Printed
-----------	------	-----------	----------	------	---------

SQ-413058

UPS Ground (up to 5 days)

9/15/2016
11:01:00AM

L Item	Description	Qty	Price	UM	Discount	Amount
15 SVS163010	VECTOR PRO-V5 TURQ.BLUE UNF 30"X10 YD	1	\$0.00	EA		\$0.00
16 SVS503010	VECTOR PRO-V5 GOLD UNF 30"X10 YD	1	\$0.00	EA		\$0.00
17 SVS13010	VECTOR PRO-V5 SILVER GRAY UNF 30"X10 YD	1	\$0.00	EA		\$0.00
18 SVS483010	VECTOR PRO-V5 VIOLET UNF 30"X10 YD	1	\$0.00	EA		\$0.00
19 V4820300	VECTOR DIAMONDBACK STD 3"X100YD	1	\$0.00	EA		\$0.00
30 V4820600	VECTOR DIAMONDBACK STD 6"X100YD	1	\$0.00	EA		\$0.00
31 V4821300	VECTOR DIAMONDBACK STD 12"X100YD	1	\$0.00	EA		\$0.00
32 V16000600	VECTOR CLEAR APP.TAPE 6"X100YD	1	\$0.00	EA		\$0.00
33 80419	4.75" Fine Hollow Point Tweezers, Polish	1	\$0.00	EA		\$0.00
34 CB09UR	GRAFTED 0.9 MM SUPERSTEEL BLADE	1	\$39.90	EA	\$39.90	\$0.00
35	0.9mm Supersteel blade with spring for cutting up to 0.25 mm thick. Use with blade holder SHELL-CB09M-WS (blue cap).	1				
36 SF-9501	FLOTTER PEN	1	\$0.00	EA		\$0.00
37 SH	SHIPPING/HANDLING	1	\$115.00	EA		\$115.00

NOTE: All shipping/handling amounts are estimates and subject to change. You will be invoiced the actual amount of shipping/handling when your order is shipped.

Tax Details
\$ 3350.27

Taxable \$5,092.99

Equipment orders in excess of \$5,000 are subject to a 3% processing fee when using a Credit Card for purchase.

Total Tax \$350.27

All quotes are valid for 30 days unless otherwise specified.

Exempt \$0.00

Total \$5,394.66

Balance \$5,394.66



USCutter
17945 NE 65th St, Suite 200, Redmond, WA 98052
425-481-3555

QUOTE

QUOTE ORDER#:
163

SALES REP:
Inside

SHIP VIA:
Flat Rate - Ground

DATE:
11/30/-0001

TIME:
12:00 AM

BILL TO ADDRESS

Howard Height
Leisure Village West
959 Buckingham Drive
Manchester, NJ 08759
US
732-657-8878

SHIP TO ADDRESS

Howard Height
Leisure Village West
1200 Route 70
Manchester, NJ 08759
US
732-657-8878

ACCT# 260716

PART#	QTY	PRODUCT	UNIT PRICE	UNIT DISCOUNT	EXT. UNIT PRICE	TOTAL
GRCC6000	1	Graphtec CE-6000 Vinyl Cutter Model: 48 in Wide - CE6000-120 Add Heat Press: No, thanks Add Starter Kit: No Thanks Add Vinyl: No, thanks Add Blades: No, thanks Add Software: No, thanks Add Parts and Accessories: No, thanks	\$3,395.00	\$0.00	\$3,395.00	\$3,395.00
ORS6514810	1	ORACAL 651 Intermediate Cal Vinyl 48" x 10 Yard Roll Color: 010 - White	\$50.99	\$5.10	\$45.89	\$45.89
ORS6514810	1	ORACAL 651 Intermediate Cal Vinyl 48" x 10 Yard Roll Color: 070 - Black	\$50.99	\$5.10	\$45.89	\$45.89
ORS6513010	1	ORACAL 651 Intermediate Cal Vinyl 30" x 10 Yard Roll Color: 049 - King Blue	\$32.00	\$3.20	\$28.80	\$28.80
ORS6513010	1	ORACAL 651 Intermediate Cal Vinyl 30" x 10 Yard Roll Color: 032 - Light Red	\$32.00	\$3.20	\$28.80	\$28.80
ORS6513010	1	ORACAL 651 Intermediate Cal Vinyl 30" x 10 Yard Roll Color: 062 - Light Green	\$32.00	\$3.20	\$28.80	\$28.80
ORS6513010	1	ORACAL 651 Intermediate Cal Vinyl 30" x 10 Yard Roll Color: 613 - Forest Green	\$32.00	\$3.20	\$28.80	\$28.80
ORS6513010	1	ORACAL 651 Intermediate Cal Vinyl 30" x 10 Yard Roll Color: 312 - Burgandy	\$32.00	\$3.20	\$28.80	\$28.80
ORS6513010	1	ORACAL 651 Intermediate Cal Vinyl 30" x 10 Yard Roll Color: 021 - Yellow	\$32.00	\$3.20	\$28.80	\$28.80
ORS6513010	1	ORACAL 651 Intermediate Cal Vinyl 30" x 10 Yard Roll Color: 082 - Beige	\$32.00	\$3.20	\$28.80	\$28.80
ORS6513010	1	ORACAL 651 Intermediate Cal Vinyl 30" x 10 Yard Roll Color: 053 - Light Blue	\$32.00	\$3.20	\$28.80	\$28.80
ORS6513010	1	ORACAL 651 Intermediate Cal Vinyl 30" x 10 Yard Roll Color: 045 - Soft Pink	\$32.00	\$3.20	\$28.80	\$28.80
ORS6513010	1	ORACAL 651 Intermediate Cal Vinyl 30" x 10 Yard Roll Color: 066 - Turquoise Blue	\$32.00	\$3.20	\$28.80	\$28.80
ORS6513010	1	ORACAL 651 Intermediate Cal Vinyl 30" x 10 Yard Roll Color: 091 - Gold (Metallic)	\$35.75	\$3.58	\$32.17	\$32.17
ORS6513010	1	ORACAL 651 Intermediate Cal Vinyl 30" x 10 Yard Roll Color: 090 - Silver Grey (Metallic)	\$35.75	\$3.58	\$32.17	\$32.17
ORS6513010	1	ORACAL 651 Intermediate Cal Vinyl 30" x 10 Yard Roll Color: 040 - Violet	\$32.00	\$3.20	\$28.80	\$28.80
B-UCSTAPE	1	GreenStar Layflat Classic Transfer Tape - Medium Tack - Assorted Widths Model: 3in x 100yd roll	\$8.99	\$0.00	\$8.99	\$8.99
B-UCSTAPE	1	GreenStar Layflat Classic Transfer Tape - Medium Tack - Assorted Widths Model: 6in x 100yd roll	\$16.99	\$0.00	\$16.99	\$16.99
B-UCSTAPE	1	GreenStar Layflat Classic Transfer Tape - Medium Tack - Assorted Widths Model: 12in x 100yd roll	\$30.99	\$0.00	\$30.99	\$30.99
B-UCSTAPECLR	1	GreenStar Layflat Clear Transfer Tape - High Tack - Assorted Widths	\$27.49	\$0.00	\$27.49	\$27.49

11/22/2016

SOI Quote

Item Code	Quantity	Description	Unit Price	Discount	Net Price	Total Price
B-UCSTAPE	1	Model: 8in x 100yd roll GreenStar Layflat Classic Transfer Tape - Medium Tack - Assorted Widths	\$76.99	\$0.00	\$76.99	\$76.99
TSPT4	1	Model: 30in x 100yd roll USCutter Weedster Tweezers	\$8.49	\$0.00	\$8.49	\$8.49
CB09UA-2	1	Graphtec 0.9mm 45° Supersteel Blades with Springs (2/pack)	\$71.50	\$0.00	\$71.50	\$71.50
PHP34-BALL	1	Graphtec Ballpoint Pen Holder PHP34-BALL for CE & FC Cutters	\$175.00	\$0.00	\$175.00	\$175.00
WHSPDONGLE	1	Add Supplies: Black Pens Signcut Productivity Pro Dongle Lifetime	\$269.99	\$0.00	\$269.99	\$269.99

Comments:

Other Support Shipping Financial Call Log Order History Sales Rep Notes
 Message Code Privacy User Stamp

Quote has no comment.

SUBTOTAL	\$4,554.35
ORDER LEVEL PROMOTIONS	(\$0.00)
ADJUSTMENTS	(\$0.00)
SALES TAX	\$0.00
SHIPPING	\$229.13
GRAND TOTAL	\$0.00
BALANCE	\$4,783.48

Thank you

TAX 318.80

5102.28

Leisure Village® West Association

AT MANCHESTER, NEW JERSEY

Interoffice Memorandum

To: Board of Trustees

From: Gene Caravella / Jim Snyder

Date: January 11, 2017

Re: Hot Water Pressure Washer with Trailer

We have been tasked with increasing our pressure washing operations and capabilities. We have investigated many options and have found equipment we feel will help achieve our goals. We have sent out an RFP for a hot water, self-contained unit with the specifications and bids received outlined below. This system will enable us to pressure wash without the need to hook up to the resident's water source.

- 24 HP electric start Honda engine with a belt driven pump.
- Minimum 12 gallon fuel tank.
- 7000lbs. Dual axle 18' heavy duty trailer.
- Minimum 725 Gallon water tank
- Twin gun system with 350' electric hose reel w/ two 250' 4000 PSI hoses.
- 50 gallon chemical tank.
- Full equipment training.

Vendor Name	Equipment Cost	Meets Specs	Shipping Costs	Tax \$ 0.07	Total Cost
Atlantic Coast	\$ 18,768.75	yes	\$ -	\$ 1,313.81	\$ 20,082.56
American Pressure Systems	\$ 18,275.00	yes	included	\$ 1,279.25	\$ 19,554.25
Power Line	\$ 22,548.00	Partial	\$ 1,842.00	\$ 1,707.30	\$ 26,097.30
Ser-U's	\$ 27,825.00	yes	\$ 300.00	\$ 1,968.75	\$ 30,093.75
Rjp Hotsy	\$ 33,216.77	yes	\$ -	\$ 2,325.17	\$ 35,541.94

It is our recommendation to purchase a completed pressure washing system from Atlantic Coast at a cost of \$20,082.56. This expense will be charged to GL # 3151 Equipment Additions.

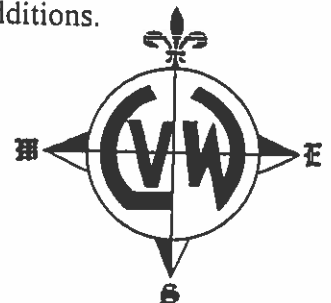

QUOTE



Atlantic Coast
 1360 Route 37 W, Toms River, NJ 08755
 Phone 732-349-2212 Fax 732-281-1116

Date: 1/10/17

Expiration Date: 30 DAYS

Notes:

To: Leisure village west

732 657 1209

Salesperson	Job Name	PO	Payment Terms
Rich			

Qty	Item #	Description	Unit Price	Discount	Line Total
1		Contained trailer package built with the following, dual 7k axle trailer with brakes on both axles wood deck, adjustable tongue, dot approved, aluminum storage box, 725 gallon potable water approved tank with hydrant fill and dump, dual high pressure electric reels (cox brand) both loaded with 250' of 2 wire 6k psi non marking hose, both reels equipped with soap injections and soap wands. 50 gal soap tank, hot water pressure washer with a honda gx690 gas engine with electric start and hr meter, belt drive pump system with triplex piston pump with a solid brass manifold, diesel burner, 2 gun pressure valve and dual heat safety's, high pressure relief valve and thermostat, machine will be plumbed to water tank with hose and high flow easy to clean filter, variety spray nozzle pack 8 total for single or dual gun operation, turnkey system with full training	28875.00		18768.75
		Stainless chassis option not added to price			1050.00
		Larger fuel tanks option not added to price			210.00

Parts Total	18768.75
Travel Charge	n/a
Labor	Inc
Freight	Inc
Subtotal	18768.75
Sales Tax	1313.81
Total	20082.56



7608 EMERALD DRIVE
WEST MELBOURNE, FL 32904

Phone # 321-254-0034

Fax # 321-914-0831

Estimate/Work Order

Date	Estimate#
12/20/2016	11619

Name / Address
Leisure Village West 959 Buckingham Drive Manchester, NJ 08759

Ship To
Leisure Village West C/O Gene Caravella 959 Buckingham Drive Manchester, NJ 08759 732-644-3384

Rep	Equipment Description
FH	TRAILER RIG

Qty	Item	Description	Price Each	Total
1	8012PRO...	Hot Water Pressure Washer System, 24 HP Electric Start Honda Motor, General Belt Drive Pump, 200 Degree Water, Beckett Diesel Burner, 12 Volt System, 8 GPM X 3500 PSI, 12 Gallon Fuel Tank's, Complete With: 50 Ft. High Pressure Hose, Gun & Wand Assembly, Chemical Injector System...	6,095.00	6,095.00
1	Misc	Twin Gun System Upcharge	495.00	495.00
1	Misc	18' x 6'10" Heavy Duty Trailer, 2 x 7000 Lb. Axles, Electric Brakes, Break Away Tongue	4,890.00	4,890.00
1	Misc	725 Gallon Water Tank With Fire Hydrant Hook-Up And Drain Kit	1,480.00	1,480.00
1	Misc	Three Galvanized Tank Bands & Plumbing Kit	590.00	590.00
1	Misc	Tool Box	230.00	230.00
2	HR300	350' ELECTRIC Hose Reel	585.00	1,170.00
2	HOS6655	Pressure Hose, 250' x 4000 PSI Non-Marking Hose	349.00	698.00
1	Misc	Lots Of Hardware And Electrical Wiring	172.00	172.00
10	Shop Labor	Shop Labor - Manufacture & Test Complete Trailer	75.00	750.00
1	Shipping	Package Trailer Unit For Shipping - Materials Only	130.00	130.00
1	Shipping	Shipping & Handling - TRUCK	1,575.00	1,575.00

QUOTATION

E-mail sales@americanpressuresystems.com

Web Site www.americanpressuresystems.com

Subtotal \$18,275.00

Sales Tax (0.0%) 1,279.25⁰⁰

Total # 19,554.25 ~~18,275.00~~



Phone 1-801-545-0777 Toll Free 800-624-8186
 Fax 1-801-545-9132
 14773 Heritage Crest Way
 Riverton, UT 84065
 e-mail: sales@powerlineindustries.com

Quote# PW 1229166

Contact Info:			Ship To:		
Leisure Village West Mr. Gene Caravella (O) 732-657-7633 (C) 732-644-3384 gcaravella@lvwservice.com			959 Buckingham Manchester, NJ 08759		
Date	Sales Rep.	P.O. No.	Contact	Terms	Tax ID
29 December 2016	LORI			½ down ½ upon shipping	

QTY	Model/Item	Description	List Price	Your Price
Complete Power Wash System- 23 HP Vanguard- Hot/ Cold/ Steam				\$19,995.00
1	Upgraded Trailer	5'x16' 10K-Sealed Wood Deck -Electric Brakes- DOT Certified in all 50 States		INCLUDED
1	TAIG23-803600 DG	24 HP-GX690 Honda- Hot Water Industrial - Electric Start-- 8 GPM @ 3600 PSI Max.		INCLUDED
1	TSF	Premium General - Triple V-Belt Driven (TBD), Pump Saver System -- Fully Adjustable - Front Mounted Pressure Gauge		INCLUDED
1	Burner System	Beckett Super High Efficiency Burner System - Extra Large for Heat Rise of 200° - 115 Volt Operation - Horizontal Coil System - Cold Rolled Continuous Schedule 80 - Rust Proof Stainless Steel Cover - Adjustable Thermostat		INCLUDED
2	Water Tank	325 gal. Lifetime Industrial Water Tank (650 gal total) with 2" fast fill		INCLUDED
1	Twin Filter System	Dual Filter Pre-Pump Filtration System 80/50 mesh		INCLUDED
2	Dual-Gun	100' HD Non-Marking Hose R-2 4,000 PSI Hose and Reel (4.5 GPM @ 3600 PSI per gun)		INCLUDED
2	E 15-5	Upgraded Electric Reels with Guide arm- holds up to 350 ft 3/8" hose	\$978.00	\$1,956.00
2	Extra Hose	150' HD Non-Marking Hose R-2 4,000 PSI (\$1.99 per ft)	\$298.50	\$597.00
1	Hose-Reel	100' Fill Hose and Reel		INCLUDED
2	Gun-Wand Assembly	36"Gun & Wand Assembly, Dual Lance Wand		INCLUDED
18	Nozzles	Nozzles (4)0, (4) 15, (4) 25, (4) 45 Degrees, (2) Turbo Nozzle		INCLUDED
1	Attachments	24" Steel Eagle Spun Aluminum Frame Heavy Duty Surface Cleaner with Side Gun and On/Off Switch & Balanced Handle Positioning for Operator Comfort, Water broom Attachment, Gutter Clean Out Tool, 12' Telescoping Wand		INCLUDED
1	Soap System	12 gal. Soap Tank, Soap Injection System		INCLUDED
1	Quick Antifreeze System	12 gal. Antifreeze Tank, Blow-Valve, Total System Recycle System		INCLUDED
1	Manual Package	(1) Parts Book, (1) Service Manual, (1) Operation Manual		INCLUDED
1	Detergents	5 gallons of Power Plus, Concrete Cleaner & Astro Wash (Make 55 gallon Drum of each)		INCLUDED
Please review carefully and note any corrections. To place this order, please sign, place the P.O. number, date and return via fax, email or just give us a call. Equipment purchases require 50% deposit, balance upon shipment.			Subtotal	\$22,548.00
Authorized Signature _____ Date _____			Shipping	\$1,842.00
			Total	\$24,390.00

TAX 1,707.30
 TOTAL 26,097.30



Serv-Us

69 J Wesley Street
 Hackensack, NJ 07606
 Cell (908) 455-2532
 SaleswithEMC@gmail.com
 Office Phone: (973) 714-1718
 Servusnj@gmail.com
 Website: <http://www.hotsy.com/>
 Website: <http://www.hydrotek.us/>

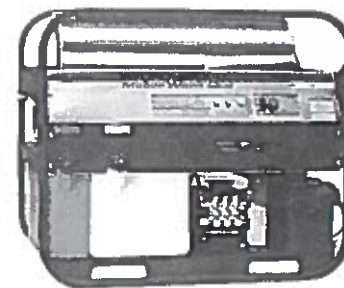

Prepared For:
 Leisure Village West
 959 Buckingham Dr
 Manchester NJ 07859
 Gene Caravella
 c-732 644 3384
 off-732 657 8878
 email-GCaravella@LVWservice.com

QUOTATION

Date 12-29-16
 Sales Consultant: ERIC CLIFF
 Phone: 908-455-2532
 Email: SaleswithEMC@gmail.com
 Estimated Ship Date: 10 - 14 Business Days

Washer Model	Part Number	Description	Qty	List Price	Discount	%/\$	Extended Price
SC35008HAF	Hydro Tek	HOT SKID 3500psi 7.7GPM 690 HONDA 2GUN	1	\$37,100.00	25	%	\$27,825.00
N/A	Cam Superliner	11,960 GVW 18' dual axle electric brake trailer w/735gal capacity	1		0	\$	
N/A	N/A	12v 250' non marking motorized hose reels	2		0	%	
	***	Recommended Accessories/Options	***				
N/A	N/A	Downstream soap injection	1		0	\$	
N/A	N/A	VARIABLE WANDS	2		0	\$	
N/A	N/A	12v Battery	1		0	\$	
	***	Recommended Detergent(s)	***				
N/A	N/A	Not a Valid Selection	1		0	\$	
N/A	N/A	Not a Valid Selection	1		0	\$	
N/A	N/A	Not a Valid Selection	1		0	\$	

THIS QUOTE IS VALID FOR THIRTY (30) DAYS

Terms & Conditions: All orders are subject to approval and acceptance by said dealer and shall be subject to the terms and conditions herein contained, and to no others whatsoever unless altered or modified by said dealer in writing. Said dealer shall be excused for any delay due to strikes, accidents, war, fires, Acts of God, or any other causes beyond our control. Promises of delivery are based on our expectations, and does not guarantee to accomplish shipment on the dates or estimated time period mentioned. Orders cannot be canceled, specifications changed, or good returned without written permission. Goods permitted to be returned are subject to restocking and freight charges.

Sub-Total	\$27,825.00
Shipping & Handling	\$300.00
Taxes 7.0%	\$1,947.75
TOTAL	\$30,072.75

TAX 1,968.75
 \$ 30,093.75

TO ACCEPT THIS QUOTATION, PLEASE SIGN & DATE HERE: _____

THANK YOU FOR THE OPPORTUNITY TO EARN YOUR BUSINESS

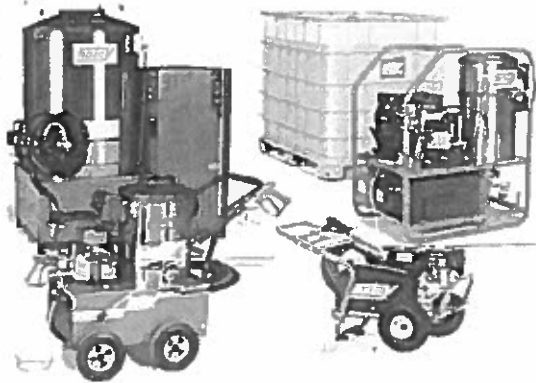

Rjp Hotsy
 17R Lakewood Rd
 New Egypt, Nj, 08533
 Phone: (609) 286-2958
 Fax: (609) 758-4629
 Email: Rjphotsy@gmail.com



Prepared For:
 Gene Caravella

QUOTATION

Date: 00/00/00
 Hotsy Sales Consultant: Ryan Wig
 Phone: 732-779-4340

Leisure Village West
 959 Buckingham Drive
 Manchester, Nj 08759
 Phone: (732) 657-8878
 Email: Gcaravella@lvwservice.com

Estimated Ship Date: 10 - 14 Business Days

Hotsy Model No.	Part Number	Description	Qty	List Price	Discount	%/\$	Extended Price
N/A	N/A	Trailer 7X18 Two 7000 LBS Axles	1		0	\$	\$5,000.00
N/A	N/A	Water Tanks 725 Gallon	1		0	\$	\$1,549.94
N/A	N/A	CoxReels 450ft Hose Reel Electric Wind Up 200 Ft Of Hose non- marking On Each Reel	1		0	\$	\$3,500.00
N/A	N/A	Two Guns With Wands	1		0	\$	\$160.00
5645	1.110-556.0	5645,Hotsy MOD HWW GENG 7 gpm /3000 Psi OIL	1	\$16,580.00	0	\$	\$16,580.00
N/A	N/A	Battery	1		0	\$	\$120.00
N/A	N/A	Two Turbo Nozzles And Soft Wash Kits	1		0	\$	\$1,220.00
N/A	N/A	Labor	1		0	\$	\$2,200.00
N/A	N/A	High Pressure Fittings/ Low Pressure Fittings /Electric	1		0	\$	\$195.97

THIS QUOTE IS VALID FOR THIRTY (30) DAYS

Sub-Total	\$33,216.77
Shipping & Handling	\$0.00
Taxes 7.0%	\$2,325.17
TOTAL	\$35,541.94

Terms & Conditions: All orders are subject to approval and acceptance by said Hotsy dealer and shall be subject to the terms and conditions herein contained, and to no others whatsoever unless altered or modified by said Hotsy dealer in writing. Said Hotsy dealer shall be excused for any delay due to strikes, accidents, war, fires, Acts of God, or any other causes beyond our control. Promises of delivery are based on our expectations, and does not guarantee to accomplish shipment on the dates or estimated time period mentioned. Orders cannot be canceled, specifications changed, or good returned without written permission. Goods permitted to be returned are subject to restocking and freight charges.

Office Use Only:

TO ACCEPT THIS QUOTATION, PLEASE SIGN & DATE HERE: _____

Nothing Cleans Like a Hotsy!

THANK YOU FOR THE OPPORTUNITY TO EARN YOUR BUSINESS

Leisure Village® West Association

AT MANCHESTER, NEW JERSEY

Interoffice Memorandum

To: Board of Trustees

From: Thomas Hasko

Date: December 30, 2016

Re: Replacement of Association HVAC (two units)

Listed below is a breakdown of the HVAC contractors that bid on replacing the two HVAC units at the Association Office. All contractors were instructed to bid on two systems. One system is currently beyond repair. Both systems are dated 1984. Bidding guidelines were a 95% Efficient two stage, Variable Speed furnace with a 16 Seer Condenser.

HVAC CONTRACTOR	PROPOSAL	TOTAL
Air Experts	\$19,016.00	\$19,016.00
BC Express	\$17,400.00	\$17,400.00
Mid-State	\$15,800.00	\$15,800.00
1 st Choice	\$15,651.00	\$15,651.00

I am requesting that the Board memorialize the payment of \$15,651.00 to 1st Choice Heating and Air Conditioning for the replacement of two HVAC units at the Association Office. This expense is charged to GL # 3230 - Capital Replacement - Common Buildings.

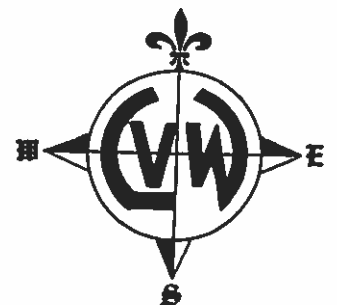



Proposal

December 29, 2016

Summary: PROPOSAL

Reference #: 1264-2241

SP: YAK

Due Date: 12/29/2016

132 Easy St. Howell, NJ 07731

o: 732.256.9149 f: 732.256.9470

www.1stchoicaircomfort.com e: info@1stchoicaircomfort.com

Master HVAC Contractor License #: 19HC00059700

Leisure Village West
1200 Route 70
Leisure Village West
Manchester, NJ 08759

Job Name:

Leisure Village West
1200 Route 70
Leisure Village West
Manchester, NJ 08759

We Hereby Submit Specifications And Estimates For:

This Proposal is for 2 full HVAC systems for the installation at: Community Center, LVW
The equipment, accessories, controls, and prices are listed for each system. The materials and work to be performed is the same for both systems.

SYSTEM 1:

EQUIPMENT:

American Standard Furnace Model #: AUH2B060A9V3 95% Efficient 2 Stage, Variable Speed
American Standard Evaporation Coil Model #: 4PXCBU30BS Upflow
American Standard SILVER Condenser Model #: 4A7A6036J 16 SEER

ACCESSORIES:

None

CONTROLS:

None

TOTAL PRICE: \$7332.00

SYSTEM 2:

EQUIPMENT:

American Standard Furnace Model #: AUH2B0809V4 95% Efficient 2 Stage, Variable Speed
American Standard Evaporation Coil Model #:4PXCBU42BS 21" Upflow
American Standard SILVER Condenser Model #:4A7A6049J 16 SEER

ACCESSORIES:

None

CONTROLS:

None

PRICE \$8319.00

TOTALC15,651.00

Proposal



132 Easy St. Howell, NJ 07731
o: 732.256.9149 f: 732.256.9470
www.1stchoiceaircomfort.com e: Info@1stchoiceaircomfort.com
Master HVAC Contractor License #: 19HC00059700

December 29, 2016
Summary: PROPOSAL
Reference #: 1264-2241
SP: YAK
Due Date: 12/29/2016

Leisure Village West
1200 Route 70
Leisure Village West
Manchester, NJ 08759

Job Name:
Leisure Village West
1200 Route 70
Leisure Village West
Manchester, NJ 08759

We Hereby Submit Specifications And Estimates For:

MATERIALS:

Sheet Metal for ductwork connections
New Pad, Whip, Disconnect
Proper flue venting and condensate drainage system
All necessary materials for a complete system

WORK TO BE PERFORMED:

Removal of existing equipment to be done by others
Install Furnace, Evap Coil, and Condenser
Install proper venting and condensate drainage system
All necessary gas, electric, flue, and duct connections for a complete system
System start up and operation check

PERMITS: 1st Choice is happy to fill out any paperwork and submit the application, however permit fees are the responsibility of Leisure Village West

WARRANTY INFORMATION:

MANUFACTURER: American Standard
Condenser/Evaporator Coil: 10 Year for 13/16 SEER,
Compressor: 10 Year Limited for 13/16 SEER
CONTRACTOR: 1st Choice Air Comfort
Labor: 1 Year

Required legalese regarding cancellation policy:
CANCELLATION:

YOU MAY CANCEL THIS CONTRACT AT ANY TIME BEFORE MIDNIGHT OF THE THIRD BUSINESS DAY AFTER SIGNING THIS CONTRACT. IF YOU WISH TO CANCEL THIS CONTRACT, YOU MUST EITHER:

- 1.) SEND A SIGNED AND DATED WRITTEN NOTICE OF CANCELLATION BY REGISTERED OR CERTIFIED MAIL, RETURN RECEIPT REQUESTED; OR
- 2.) EMAIL A SCANNED COPY OF A SIGNED AND DATED WRITTEN NOTICE OF CANCELLATION TO: admin@1stchoiceaircomfort.com
- 3.) PERSONALLY DELIVER A SIGNED AND DATED WRITTEN NOTICE OF CANCELLATION TO:
1st Choice Air Comfort 132 Easy St. Howell, NJ 07731 732.256.9149



Proposal

132 Easy St. Howell, NJ 07731
o: 732.256.9149 f: 732.256.9470
www.1stchoiceaircomfort.com e: info@1stchoiceaircomfort.com
Master HVAC Contractor License #: 19HC00059700

December 29, 2016
Summary: PROPOSAL
Reference #: 1264-2241
SP: YAK
Due Date: 12/29/2016

Leisure Village West
1200 Route 70
Leisure Village West
Manchester, NJ 08759

Job Name:
Leisure Village West
1200 Route 70
Leisure Village West
Manchester, NJ 08759

We Hereby Submit Specifications And Estimates For:

If you cancel this contract within the three day period, you are entitled to a full refund of your money. Refunds must be made within 30 days of the contractor's receipt of the cancellation notice. This contract is null and void if work has not commenced within 30 days from receipt of deposit. The proposal may be revised to reflect any changes and any cost adjustments associated with the change and an acceptance signature is required before work can begin. If the new terms are not acceptable, the homeowner will receive a refund for the amount of the deposit less any expenses 1st Choice has incurred under the existing contract. All work contingent on delays beyond our control: 1st Choice reserves the right to stop work until any and all interferences are resolved to all parties' satisfaction.

Please look over the proposal carefully and reach out to Chris directly at 732.256.9149 with any questions. If it all looks good, please sign where it say's "Acceptance Signature" and return to us. Thank you for choosing 1st Choice!

We propose hereby to furnish material and labor - complete in accordance with the above specifications, for the sum of: \$15,651.00

Payment to be made as follows:

50% Down, 50% Due Upon Completion

All material is guaranteed to be as specified. All work to be completed in a professional manner according to standard practices. Any alteration or deviation from above specifications involving extra costs will be executed only upon written orders and will become an extra charge over and above the estimate. All agreements contingent upon delays beyond our control. Purchaser agrees to pay all costs of collection, including attorney's fees. This proposal is good for 30 days and may be withdrawn by us if not accepted by the above due date. Customer has 3 days after signing proposal to cancel. Final payment is due upon completion.

Authorized
Signature _____

Acceptance
Signature _____

Date _____

PROPOSAL/ AGREEMENT



AIR EXPERTS INC.
Sales • Service • Installation
"EXPERT SERVICE MAKES SATISFIED CUSTOMERS"
24 Hour Emergency Service
727-C 17th Ave. Lake Como, N.J. 07719
(732) 681-9090 (732) 280-2213 Fax

Date: **DECEMBER 30, 2016**

Proposal Submitted To: Name: LEISURE VILLAGE WEST	Work To Be Performed At: Name: AIR EXPERTS HVAC LICENSE
Address: 1200 ROUTE 70 MANCHESTER, NJ 08759	Address: 19HC00123400
Home Phone: Cell Phone: 732-681-0341 Work Phone:	Phone:

We propose to furnish, install, and service under guarantee (stated below) products or related equipment for your home in accordance with the condition and specifications set forth below

Job Type: Replacement New Ductwork Only Conversion Oil or Electric Add-on

Referred By: Yellow Pages Existing Customer Local Paper Website Other: _____

Is there more than 1 zone? Yes No If yes, How many? **2**

EQUIPMENT INFORMATION

Type	Qty	Seer	BTU	AFUE	Brand/Model	Zone
Furnace	1		70K	96%	LENNOX ELITE EL296UH07DXV36B VARIABLE SPEED	SYSTEM 1
Boiler	1		90K	96%	LENNOX ELITE EL296UH090XV48C VARIABLE SPEED	SYSTEM 2
Heat Pump						
Condenser	1	15	36K		LENNOX ELITE XC14S036-230 R-410	SYSTEM 1
Coil	1	15	36K		LENNOX CX34-36B-6F R-410A	SYSTEM 1
Air Handler						
Hot Water Heater	1	15	48K	CONDENSER	LENNOX ELITE XC14-048-230 R-410A	SYSTEM 2
Humidifier	1	15	48K	COIL	LENNOX CX34-49C-6F R-410A	SYSTEM 2
Air Cleaner					VISIT TO JOB SITE LOCATION HAS TO BE DONE BEFORE	
Ductless Split					AIR EXPERTS CAN FINALIZE INSTALL COST ON PROPOSAL	
Manufacturer Extended Warranty						
Thermostat	2				HONEYWELL PROFOCUS6000	

DUCTWORK/AIR DISTRIBUTION

<input type="checkbox"/> New supply(s) including all associated heavy gauge ductwork and diffusers. _____ <input type="checkbox"/> New returns including all associated heavy gauge ductwork and grille(s). _____ <input type="checkbox"/> Complete supply air trunk system with all required branch and return ductwork.	<input type="checkbox"/> High "R" Fiberglass duct insulation <input checked="" type="checkbox"/> Plenum modification <input type="checkbox"/> Balance air distribution system for uniform temperature Air Experts, Inc. assumes no liability for air flow on duct systems installed by others <input type="checkbox"/> Other _____
---	--

INSTALLATION

<input checked="" type="checkbox"/> Opt-sized refrigerant line with armatflex insulation <input checked="" type="checkbox"/> Primary condensate drain <input type="checkbox"/> Secondary condensate drain <input checked="" type="checkbox"/> Condensate pump <input type="checkbox"/> Architectural exterior refrigerant line enclosure <input checked="" type="checkbox"/> All work done in accordance with existing codes <input type="checkbox"/> All required permits - COST NOT INCLUDED Bk# _____ Lot# _____ <input type="checkbox"/> Customer declines getting permits <input checked="" type="checkbox"/> Removal of existing equipment from premises <input checked="" type="checkbox"/> Pre-cast reinforced concrete slab <input checked="" type="checkbox"/> All work performed by Class 1 Certified Technicians <input type="checkbox"/> Vibration isolating shock absorbers <input checked="" type="checkbox"/> Gas Piping _____ <input checked="" type="checkbox"/> Other TOWNSHIP PERMITS INCLUDED IN PROPOSAL	<input checked="" type="checkbox"/> Complete clean up including vacuuming and use of drop clothes for the protection of home furnishings. <input type="checkbox"/> Chimney Liner <input type="checkbox"/> Standard <input type="checkbox"/> Stainless <input type="checkbox"/> Event <input type="checkbox"/> PVC <input checked="" type="checkbox"/> Chimney conditions: PVC SIDEWALL TERMINATION KIT <input checked="" type="checkbox"/> The cooling system will produce a minimum of 75 °inside at the thermostat on a 95 ° day. <input checked="" type="checkbox"/> The heating system will produce a minimum of 70 °inside at the thermostat on a 0 ° day. <input type="checkbox"/> Heating Tune-up-Per ESA Agreement Sign-on <input type="checkbox"/> A/C Tune-up- Per ESA Agreement Sign-on <input checked="" type="checkbox"/> Application <input type="checkbox"/> Basement <input type="checkbox"/> Crawlspace <input type="checkbox"/> Attic <input type="checkbox"/> Living Area Are blocks needed? <input type="checkbox"/> Yes <input type="checkbox"/> No <input type="checkbox"/> Rebates: JCPL - in accordance to guidelines in affect at time of installation <input checked="" type="checkbox"/> Rebates: NJNG - in accordance to guidelines in affect at time of installation
--	--

ELECTRICAL/CONTROLS

<input checked="" type="checkbox"/> New weather proof disconnect <input checked="" type="checkbox"/> Whip _____ <input type="checkbox"/> New _____ amp electric circuit from existing panel with required automatic breakers	<input checked="" type="checkbox"/> Other AIR EXPERTS 2 YEAR LABOR WARRANTY LENNOX 10 YEAR PARTS WARRANTY
--	--

All material is guaranteed to be as specified, and the above work to be performed in accordance with drawings and specifications submitted for above and completed in a substantial workmanlike manner for the sum of \$ **19016.00** with payments to be made as follows:

Deposit \$ _____ Payment #2 \$ _____ Payment #3 Balance Due Upon Completion to be given to installer \$ _____

Method of Payment: (Circle Which Applies) Check Credit Card Financing Other: _____

Respectfully submitted _____ Date _____

NOTE: This proposal may be withdrawn by us if not accepted within 30 days.

ACCEPTANCE OF PROPOSAL/AGREEMENT

The price, specifications, and terms and conditions are satisfactory and are hereby accepted. You are authorized to do the work as specified. Payments will be made as outlined above.

Company Approval: _____ Date _____

Customer Approval (Print Name): _____ Date _____

Customer Approval (Sign Name): _____ Date _____

DISTRIBUTION White-Air Experts, Inc. Acceptance Copy Yellow-Customer Acceptance Copy Pink-Air Experts, Inc. File Copy



MID-STATE



TOLL FREE 1-800-536-7199

Toms River
(732) 349-6110

Red Bank
(732) 842-7199

Freehold
(732) 780-0050

Edison
(732) 549-3353

Somerset
(908) 685-8288

Fax
(732) 758-9466

GENERATORS • AIR CONDITIONING • HEATING • SERVICE AGREEMENTS • ELECTRIC • PLUMBING

PROPOSAL SUBMITTED TO: <u>LEISURE VILLAGE WEST</u>		DATE: <u>12-28-16</u>	START DATE:	COMPLETION DATE:
STREET: <u>1200 RT 70</u>		NEAREST CORNER:	PLG. LIC # <u>12207</u>	NJ LIC. <u>13VH00590600</u>
CITY, STATE, AND ZIP CODE: <u>MANCHESTER, NJ 08759</u>		JOB NAME AND LOCATION:		
HOME PHONE:	WORK PHONE:	CELL NUMBER: <u>TOM</u> <u>732-681-0341</u>	BLOCK:	LOT:
ELECT. LIC. # <u>17383</u>				

Equipment

One (1) Outside Condensing Unit: XR16-036 BTU Capacity: 36,000 Up to 16 S.E.E.R.

One (1) Inside Cooling Coil: VERTICAL COIL

One (1) Heating Unit: XV95-060 BTU Capacity: 60,000 A.F.U.E. 97.90

One (1) Outside Condensing Unit: XR16-048 BTU Capacity: 48,000 Up to 14.5 S.E.E.R.

One (1) Inside Cooling Coil: VERTICAL

One (1) Heating Unit: XV95-080 BTU Capacity: 80,000 A.F.U.E. 97.90

One (1) Hot Water Heater: _____ Gallon: _____ E.F. _____

One (1): _____

PERMITS ARE BILLED AT \$50.00 PLUS MUNICIPAL COST

Installation Includes

- All Necessary: DISPOSE OF OLD EQUIPMENT. INSTALL TWO NEW FURNACE, COIL & CONDENSERS. REUSE R/C CONNECT TO EXISTING PVC VENTS. INSTALL NEW CONDENSATE PUMPS
- Duct Modifications: DIETONIC. RUN NEW PEPERBERNS LINES. REUSE EXISTING PVC VENTS. INSTALL NEW CONDENSATE PUMPS

3) Piping Modifications: _____

4) Warranty: Manufacturer TRANE Years Parts: 10 Years Labor: 2

Compressor Parts 10 Heat Exchanger Parts _____

12 MONTHS PARTS & LABOR ON ALL OTHER SYSTEM COMPONENTS

THE ABOVE INSTALLATION WILL BE COMPLETED FOR THE SUM OF: \$ 15,800

Home Comfort Options

We carry the finest indoor air quality products such as energy saving thermostats, electronic air cleaner, UV lights & humidifiers.

Air Cleaner - Electronic or Media, Size _____ x _____	\$ _____	\$ _____
Energy Saving Thermostat <u>TWO HONEYWELL T-6 STATS</u>	\$ _____	\$ <u>JNG</u>
Humidifier	\$ _____	\$ _____
Electric / Panel Upgrade	\$ _____	\$ _____
Maintenance Agreement (s)	\$ _____	\$ _____
Extended Warranty	\$ _____	\$ _____
Misc.	\$ _____	\$ _____
Misc.	\$ _____	\$ _____